

Hydraulik cylindre

Standardprogram



05.01.2009/rev00. Forbehold for trykfejl og prisændringer.

Cylindre serie 700

Bestillings nr.	Lager vare	øA	øB	Slaglængde	L-minimum	C	D	F	G	H	I	J	K	L	Tilslutning	Vol	Vægt																						
		mm	mm													mm	E= mm	mm	mm	mm	mm	mm	mm	litr.	Kg														
2516050F12	x	16	25	50	160	12,1	12,1								1/4																								
2516100F12	x			100	210																																		
2516150F12	x			150	260																																		
2516200F12	x			200	310																																		
3220050F16	x	20	32	50	205	16	16,2	35	40	28	30	47	35	9,5	1/4	0,04	1,7																						
3220100F16	x			100	255																			0,08	2														
3220150F16	x			150	305																				0,12	2,3													
3220200F16	x			200	355																					0,16	2,6												
3220300F16	x			300	455																						0,24	3,2											
4025100F20	x	25	40	100	270	17,5	20,25	40	50	64,5	35	38,5	40	15	3/8	0,13	2,9																						
4025150F20	x			150	320																						0,19	3,4											
4025200F20	x			200	370																							0,25	3,8										
4025300F20	x			300	470																								0,38	4,7									
4025400F20	x			400	570																									0,5	5,7								
4025500F20	x			500	670																										0,63	6,6							
4025800F20	x			800	970																											1,1	9,3						
5030100F25	x	30	50	100	300	22	25,25	45	60	85	40	43	43	15	3/8	0,2	4,3																						
5030150F25	x			150	350																											0,3	5						
5030200F25	x			200	400																												0,39	5,6					
5030300F25	x			300	500																													0,59	6,8				
5030400F25	x			400	600																														0,79	8			
5030500F25	x			500	700																															0,98	9,5		
5030600F25	x			600	800																																1,18	10,5	
5030700F25	x			700	900																																	1,37	11,7
5030800F25	x			800	1000																																		1,55

Tekniske data

CYLINDER RØR - SVEJSEDE KOLDTRUKNE RØR

Materiale: ST52-3 DIN2393
 Certifikat: EN10204 3.1B / EN29002
 Invendig tolerance: 25 mm til 100 mm H9
 Invendig tolerance: >100 mm H8
 Ruhed: RA 0,4 - 0,8 µm

STEMPELSTANG

Materiale: CK45
 Certifikat: DIN17200 - EN 10204/2.2
 Krom tykkelse: 20 µm
 Krom hårdhed: Min. 900 HV
 Ruhed: -RA < 20 µm
 Porøsitet: BSS 4641 B
 Tolerance: ISO F7
 Lighed: 0,2 mm på 1000 mm
 Korrosion test: EN 4540 klasse 8/9 - 120 t

Tilladte ridser/mærker: Mindre end 10µm

CICROSA modtager et certifikat af materialet for alle stænger og rør leveret fra producent. Certifikatet skal sikre, at kvaliteten er som beskrevet.

GUIDE RINGE FOR STEMPELSTANG

Materiale: Polyuretan 94 shore
 Arbejdstemperatur: -30°C til +90°C
 Tolerance for guide ringe: H9
 Anbefalet max. hastighed: 0,5 m/s

PAKNING I FORRESTE HOVED

Materiale invendig backup ring: NBR 90s + METAL
 Anbefalet max. hastighed: 1 m/s

Materiale O-ring: NBR 70 shore

PAKNING FOR HYDRAULISK STEMPEL

Materiale: Polyurethane + NBR 70 shore
 Max. tryk: 250kg/cm²
 Tolerance på fordybning på pakning: H9

GUIDE RING FOR HYDRAULIK STEMPEL

Materiale: POM + Glass
 Max. radial belastning: 400kg/cm²

Hydraulik stemplet er støttet med backup-ring og en guide-ring, som giver en meget god og stærk lukning i begge retninger. Den forventede levetid er beregnet til 300.000 meters slaglængde, baseret på normale arbejdsbetingelser.

Cylindre serie 1000

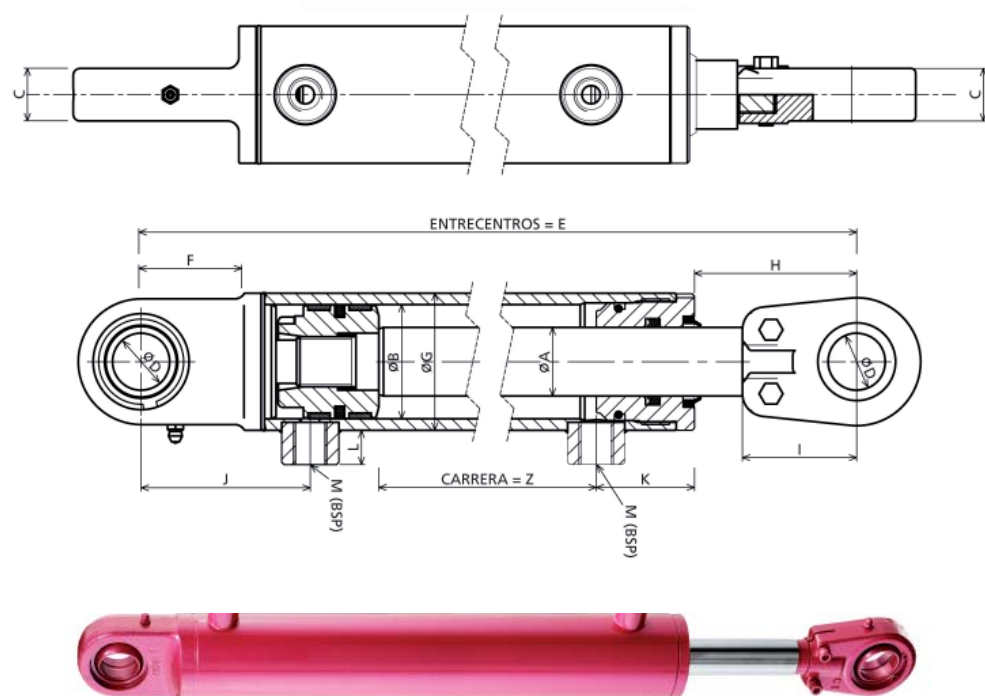

Cylindre serie 700

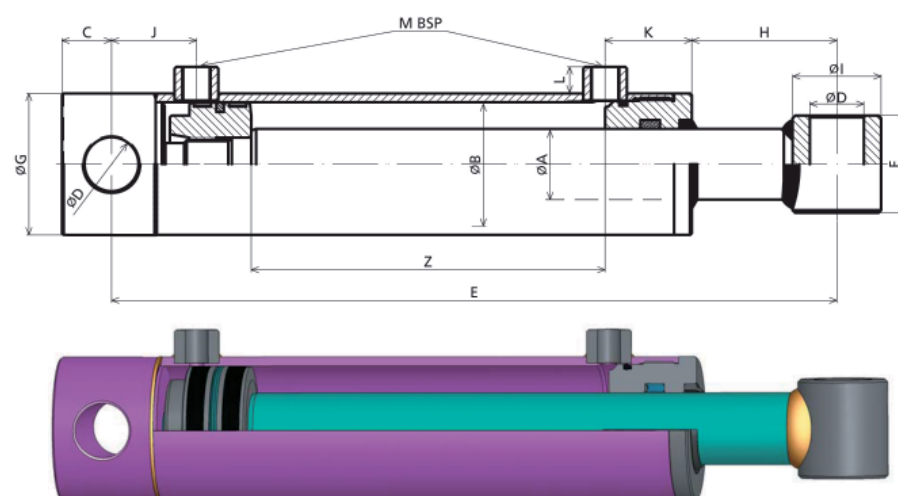

Bestillings nr.	Lager vare	øA	øB	Slaglængde	L-minimum E= mm	C	D	F	G	H	I	J	K	L	Tilslutning	Vol ltr.	Vægt Kg
		mm	mm														
6030100F25	x	30	60	100	300	22	25,25	45	70	83	40	43	45	15	3/8	0,28	5,4
6030150F25	x			150	350											0,42	6,2
6030200F25	x			200	400											0,57	7
6030300F25	x			300	500											0,85	8,1
6030350F25	x			350	550											0,99	8,8
6030400F25	x			400	600											1,13	9,5
6030500F25	x			500	700											1,41	10,8
6030600F25	x			600	800											1,7	12,2
6030700F25	x			700	900											1,98	13,5
7040200F30	x	40	70	200	410	28	30,5	55	80	82	50	48	49	15	3/8	0,77	10
7040300F30	x			300	510											1,15	11,9
7040350F30	x			350	560											1,34	12,8
7040400F30	x			400	610											1,54	13,7
7040500F30	x			500	710											1,92	15,6
7040600F30	x			600	810											2,31	17,5
7040700F30	x			700	910											2,69	19,4
8040200F30	x	40	80	200	410	28	30,5	55	90	70	50	48	54	15	3/8	1,01	12
8040250F30	x			250	460											1,26	13
8040300F30	x			300	510											1,51	14
8040400F30	x			400	610											2,01	16
8040500F30	x			500	710											2,51	18,1
8040600F30	x			600	810											3,02	20,1
8040700F30	x			700	910											3,52	22,1
8040800F30	x			800	1010											4,02	24,1
10050300F30	x	50	100	300	525	28	30,5	70	115	75	60	48	60	17	1/2	2,36	25,6
10050400F30	x			400	625											3,14	28,5
10050500F30	x			500	725											3,93	31,4
10050700F30	x			700	925											5,5	37,2
10050900F30	x			900	1125											7,07	43

Cylindre serie 1000

Bestillings nr.	Lager vare	øA	øB	Slaglængde	L-minimum	C	D	F	G	H	I	J	K	L	Tilslutning	Vol	Vægt
		mm	mm													mm	E= mm
3220050S20		20	32	50	260	19	20	38	40	67	50	55	33	9,5	1/4	0,04	2,08
3220100S20				100	310											0,08	2,38
3220150S20	x			150	360											0,12	2,68
3220200S20				200	410											0,16	2,98
3220300S20				300	510											0,24	3,28
4020050S20	x	20	40	50	255	19	20	38	50	70	50	68	40	15	3/8	0,06	2,63
4020125S20	x			125	330											0,16	3,24
4020150S20	x			150	355											0,19	3,44
4020200S20	x			200	405											0,25	3,84
4025100S20	x	25	40	100	305	19	20	38	50	70	50	68	40	15	3/8	0,13	3,34
4025200S20	x			200	405											0,25	4,28
4025300S20	x			300	505											0,38	5,23
4025400S20	x			400	605											0,5	6,18
4025500S20	x			500	705											0,63	7,13
5025100S25	x	25	50	100	320	23	25	45	60	71	50	77	43	15	3/8	0,2	4,05
5025150S25	x			150	370											0,29	4,56
5025200S25	x			200	420											0,39	5,06
5025250S25	x			250	470											0,49	5,56
5030100S25		30	50	100	320	23	25	45	60	71	50	77	43	15	3/8	0,2	4,44
5030150S25	x			150	370											0,3	5,05
5030200S25	x			200	420											0,39	5,62
5030300S25	x			300	520											0,59	6,8
5030350S25	x			350	570											0,69	7,35
5030400S25	x			400	620											0,79	7,98
5030450S25	x			450	670											0,9	8,6
5030500S25	x			500	720											0,98	9,16
5030600S25	x			600	820											1,18	10,34
5030700S25				700	920											1,37	11,52

6030100S30	x	30	60	100	340	28	30	51	70	83	60	83	45	15	3/8	0,28	6,15
6030200S30	x			200	440											0,57	7,51
6030300S30	x			300	540											0,85	8,87
6030400S30	x			400	640											1,13	10,23
6030500S30	x			500	740											1,41	11,59
6030600S30	x			600	840											1,7	12,95
6030700S30				700	940											1,98	14,31
7040200S35		40	70	200	470	30	35	61	80	95	70	95	49	15	3/8	0,77	11,03
7040300S35				300	570											1,15	12,94
7040400S35	x			400	670											1,54	14,85
7040500S35				500	770											1,92	16,76
7040600S35				600	870											2,31	18,67
7040700S35				700	970											2,69	20,58
7040800S35	x	800	1070	3	22,48												
8040200S35	x	50	80	200	480	30	35	61	90	93	70	95	54	15	3/8	1,01	12,95
8040300S35	x			300	580											1,51	14,98
8040400S35	x			400	680											2,01	17,01
8040500S35	x			500	780											2,51	19,04
8040600S35				600	880											3,01	21,07
8040700S35				700	980											3,51	23,1
10050300S40		50	100	300	625	35	40	69	115	118	85	105	60	17	1/2	2,36	26,37
10050400S40				400	725											3,14	29,89
10050500S40				500	825											3,93	33,41
10050700S40				700	1025											5,5	40,45
10050900S40				900	1225											7,07	47,49



DANMARK

DANI-TECH A/S

Bredholm 4 - DK-6100 Haderslev
tlf. +45 7634 2300 - fax. +45 7634 2301
infodk@dani-tech.com - www.dani-tech.com



DANMARK

DANI-TECH SUPPORT A/S

Bredholm 4 - DK-6100 Haderslev
tlf. +45 7634 2305 - fax. +45 7634 2301
infodk@dani-tech.com - www.dani-tech.com



HOLLAND

DANI-TECH B.V.

Energieweg 41 A - 2382 NC Zoeterwoude
tlf. +31 (0) 71 5417704 - fax. +31 (0) 71 5419106
infonl@dani-tech.com - www.dani-tech.com



SVERIGE

DANI-TECH SVENSKA AB

Verkstadsvägen 1 - 245 34 Staffanstorp
tlf. +46 (0) 46-233060 - fax. +46 (0) 46-233069
infose@dani-tech.com - www.dani-tech.com



ITALIEN

BONDIOLI & PAVESI S.P.A

Via 23 Aprile, 35/a - I-46029 SUZZARA (MN)
tlf. +39 03765141 - fax. +39 0376514444
bypy@bypy.it - www.bondiolli-pavesi.com

Alle tekniske illustrationer i denne brochure er ikke bindende.
Dani-tech A/S forbeholder enhver ret til ændringer i dette brochuramateriale uden forudgående varsel.

